

BPW

series

使用範圍：水處理、空調、雨水回收設備等...

工作壓力：0.98Mpa (10kgf/cm²)

工作溫度：10°C ~ 100°C

接續規格：Wafer type (JIS10K)



S80-BPW



S150-BPW

ITEM	PARTS	MATERIAL
1	BODY	PVC/PP/PVDF
2	DISC	PVC/PP/PVDF
3	SEAT SEAL	EPDM/FPM
4	STEM	SUS410
5	O-RING	EPDM / FPM
6	O-RING	EPDM / FPM

Unit [mm]

IN	SIZE	D1	D2			∅D3	H2	W1	W2	n			∅e		
			JIS	ANSI	DIN					JIS	ANSI	DIN	JIS	ANSI	DIN
2	DN50	165	120	120.4	125	56.5	103	42	35	4	4	4	19	19	18
2 1/2	DN65	185	140	139.4	145	70	113	46	37	4	4	4	19	19	18
3	DN80	200	150	152.4	160	79	115	46	37	8	4	8	19	19	18
4	DN100	229	175	190.5	180	103	135	56	47	8	8	8	19	19	18
5	DN125	256	210	216	210	130	150	66	50	8	8	8	23	22	18
6	DN150	285	240	241.5	240	151	177	71	62	8	8	8	23	22	23
8	DN200	343	290	298.5	290	200	210	87	68	12	8	8	23	23	23

S80

BPW series

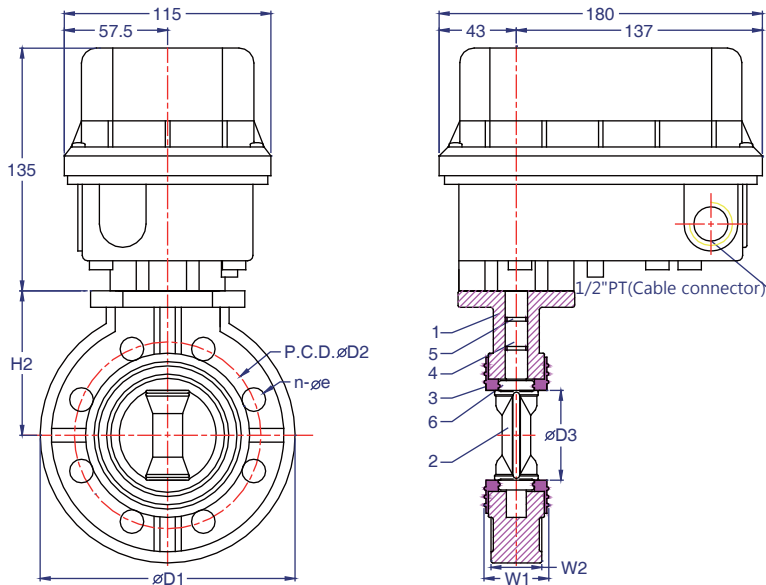

型號	S 35-BPWXX	S 37-BPWXX	S 38-BPWXX	S 80-BPWXX	PS 35-BPWXX	PS 38-BPWXX
閥體尺寸 (mm)	DN50 to DN65	N/A	DN50 to DN80	DN50 to DN80	DN50 to DN65	DN50 to DN80
供應電壓 50/60Hz	AC220V ±10%				AC220V ±10%	
控制信號	ON-OFF				0/4~20mA, 1/2~10mA, 0/2-10Vdc	
最大電流 (A)	0.3	0.5	0.3	0.5	0.3	0.3
運轉電流 (A)	0.2	0.3	0.2	0.3	0.2	0.2
運轉時間 (50Hz)	60sec	8sec	95sec	16sec	60sec	95sec
運轉時間 (60Hz)	50sec	7sec	75sec	15sec	50sec	75sec
消耗功率 (W)	10	70	10	70	10	10
運轉週期	連續運轉	非連續運轉	連續運轉	非連續運轉	連續運轉	連續運轉
運轉週期備註	非連續運轉: O-15min-CO-10min					
絕緣等級	E class insulation					
防護等級 / 防護材質	IP66 (相當屋外防水) / 上蓋:PC, 底座:PA66+GF45, 止水環:NBR					
周圍環境溫度	-10°C to 50°C					
周圍環境溼度	90%RH Max. (non-condensing)					
電器連接	1/2" PT cable connector, screw terminals					
電線接續方法	1.25mm 線徑				1.25mm 線徑(隔離線)	
選購加裝	輔助接點 2 (SPDT) / 反饋信號 1KΩ / 空間加熱器 / 加高架				4~20mA Feedback	

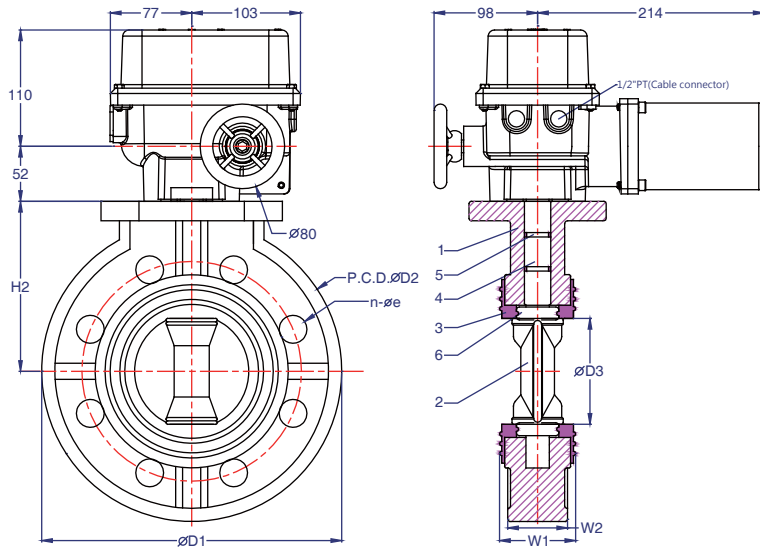

S150

BPW series

型號	S150-BPWXX	S151-BPWXX	S152-BPWXX	PS151-BPWXX	PS152-BPWXX	
閥體尺寸 (mm)	DN100 to DN150	DN100 to DN150	DN100 to DN200	DN100 to DN150	DN100 to DN200	
供應電壓 50/60Hz	AC220V ±10%				AC220V ±10%	
控制信號	ON-OFF				0/4~20mA, 1/2~10mA, 0/2-10Vdc	
最大電流 (A)	2	0.6	0.6	0.6	0.6	
運轉電流 (A)	1	0.5	0.5	0.5	0.5	
運轉時間 (50Hz)	9sec	50sec	100sec	50sec	100sec	
運轉時間 (60Hz)	8sec	40sec	80sec	40sec	80sec	
消耗功率 (W)	185	80	80	80	80	
運轉週期	非連續運轉 60%	非連續運轉 75%	非連續運轉 75%	非連續運轉 75%	非連續運轉 75%	
運轉週期備註	非連續運轉: 60%: O-15min-CO-10min. 75%: O-75min-CO-25min					
絕緣等級	E class insulation					
防護等級 / 防護材質	IP66 (相當屋外防水) / 上蓋:PC, 底座:鑄鋁合金, 止水環:NBR					
周圍環境溫度	-10°C to 50°C					
周圍環境溼度	90%RH Max. (non-condensing)					
電器連接	1/2" PT cable connector, screw terminals					
電線接續方法	1.25mm 線徑			1.25mm 線徑(隔離線)		
選購加裝	Auxiliary switches 2 (SPDT) / 電位計 Potentiometer 1KΩ / 空間加熱器 Heater			4~20mA Feedback		